

IBC



High Precision Locknuts

Seal Ring Locknuts
Labyrinth Seals

TI-I-5020.1/E



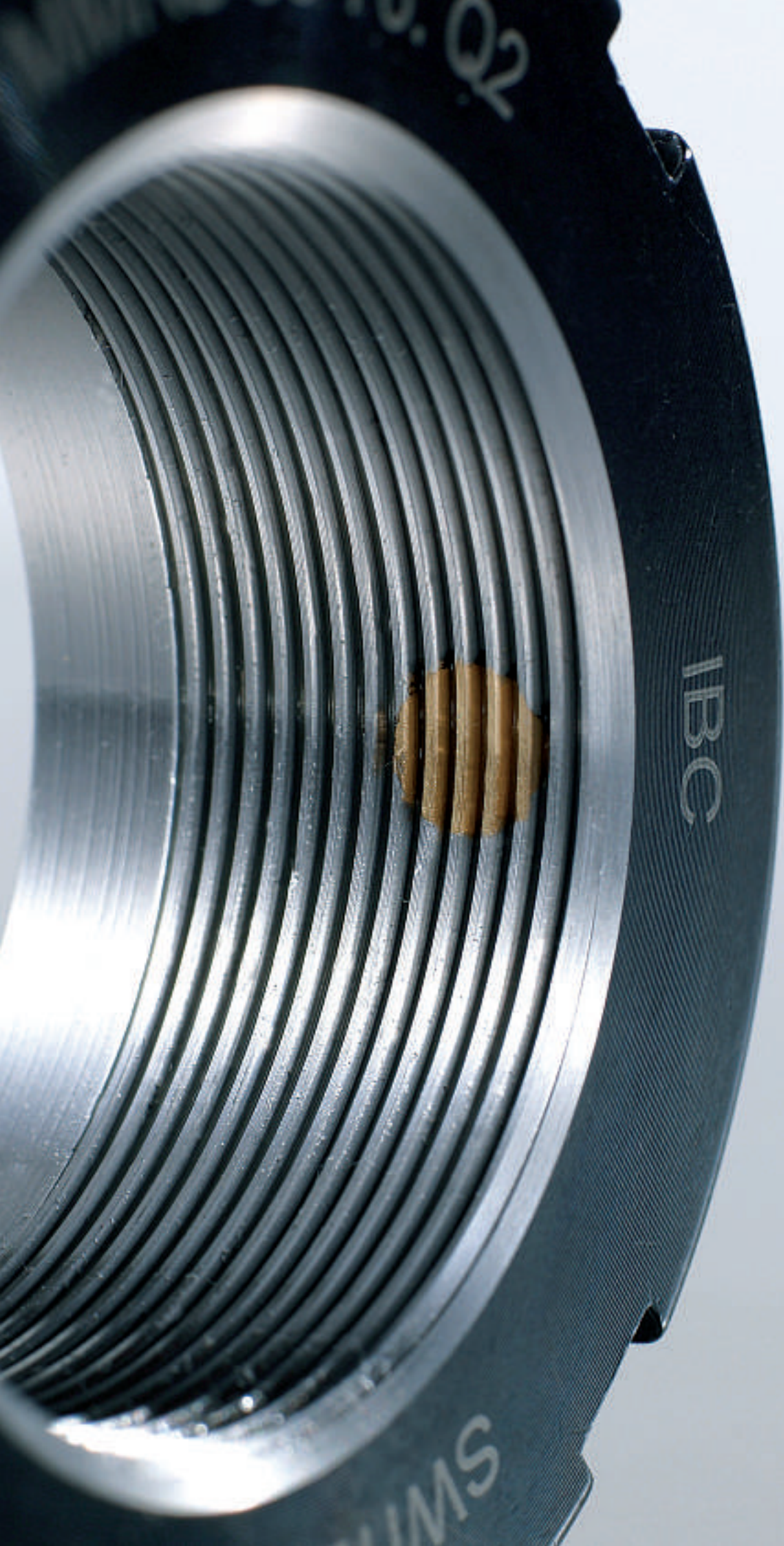

Table of contents

1. Introduction	4
1.1 Production series	5
1.2 Tolerances	5
1.3 Mounting dimensions	5
1.4 Strength of the locknut threads	6
1.5 Mounting	6
1.6 Securing against loosening	6
1.7 Dismounting	7
2. IBC precision locknuts MMR, MMRB / MMRBS	8
3. IBC precision locknuts MBA / MBAS, MBC, MMA	10
4. IBC precision labyrinth seals S series	12
IBC precision seal ring locknuts MD series	12
5. IBC precision labyrinth groove locknuts MMRS	14
6. Mounting and preloading IBC precision bearings with IBC precision locknuts	15
6.1 Preparation	15
6.2 Checking the adjacent parts	15
6.3 Mounting	15
6.3.1 Mounting after heating the bearing	15
6.3.2 Breakaway torques M_L of the precision locknut	16
6.4 Calculating the locknut tightening torque T	16
6.4.1 Calculating the tightening torque T_a needed to fit the bearings	16
6.4.2 Calculating the minimum required preload torque M_D	17
6.4.3 Example: spindle bearing, from preload	18
6.4.4 Example: spindle bearing, from contact pressure	19
6.4.5 Example: ball screw bearing	19
6.5 Mounting high precision rolling bearings with tapered bore	19
7. Examples of application for IBC precision locknuts and labyrinth seals	20
8. IBC precision locknuts and labyrinth seals coated with ATCoat coating	22

1. Introduction

High precision locknuts and labyrinth seals are an established and integral part of the extensive and time-tested range of rotative rolling bearings manufactured by IBC Wälzlager GmbH, Industrial Bearings and Components. IBC high precision locknuts with fine thread are mainly used in machine tools with the bearings of ball screws and main spindles, therefore their dimensions have been matched to the mounting dimensions of high precision bearings (**High Precision Bearings TI-I-5050, Ball Screw Support Bearings TI-I-5010.3**). The locknuts have also been designed to fit a great variety of precision bearing applications.

The performance of a machine tool spindle mainly depends on fixing its precision bearings and other machine parts on the shaft in a secure and plane-parallel manner. Because of their high precision, IBC high precision locknuts are also suited to fixing machine parts that are used in other industrial areas. There, too, they will ensure that the parts are permanently positioned in an exact and reliable manner.

The securing systems integrated into the various high precision locknuts guarantee simple and accurate mounting and provide for lasting stability. There is no longer any need to provide locking grooves in shafts that are meant to hold locking washers. This will reduce the occurrence of the notch effect. High precision locknuts can also be re-used without losing any of their precision.

The great variety of possible applications along with their diverse bearing requirements led us to develop a modular system that provides the design engineer with great flexibility when designing different versions. These bearing requirements include axial stiffness and load rating, low heat generation through low friction as well as rotational speeds and running accuracy.

High precision locknuts and labyrinth seals are components in the comprehensive IBC modular system. The system enables users to realise application-specific integrated solutions in a fast and easy manner, resulting in high precision bearing units that are ready for mounting. IBC high precision bearing units are lubricated for life and are sealed with labyrinth seals. They are designed for ball screws that are most commonly used in machine tools as well as in measuring and handling devices and in sheet-metal processing, woodworking and special-purpose machines. Apart from offering a standard range of high precision cartridge or pillow block units, IBC also manufactures all kinds of special solutions according to a customer's specifications.



Fig. 1: IBC high precision locknut of the MBA series with axial locking devices

1.1 Production series

The different production series of IBC high precision locknuts are suited to a wide range of applications and loads. The high precision locknuts are manufactured in various widths suitable for different axial loads. The locking devices may be axially or radially accessible, depending on the design.

For applications with limited installation space, or in order to save weight, we recommend using precision locknuts from the **MMR** series, which have radially acting locking devices (see pages 8 and 9). In the **MBA** and **MBC** series (see pages 10 and 11), the locking of a precision locknut in a recessed place of operation which cannot be reached radially (housing bores) is carried out via axially accessible pressure or clamping screws. This production series requires a greater width due to its specific design. The securing system of the MBA design can slightly increase the axial preload of the precision locknut, whereas in the MBC design it can slightly decrease axial preload. The MBA design is available from a thread diameter of 20 mm. Its permissible axial load is the same as for the MMR precision locknut. Starting from a thread diameter of 45 mm up to a thread diameter of 300 mm, the locknuts of the MBC series are also manufactured with four internal hexagon socket screws. The **MMRB** execution has a radial locking device, and its cross section is the same as the MBA and MBC precision locknuts; it therefore permits higher loads and higher tightening torques. This is a special advantage if you want to preload bearings that support a high axial load (for instance in the case of ball screws).

Under the designation **MMRBS** and **MBAS**, the above-mentioned MMRB and MBA production series are also manufactured with an integrated labyrinth seal (see pages 8 to 11). These series additionally have a set of Laminar rings made of spring steel. Together with a matched housing, the set of rings creates a compact labyrinth seal in cases where limited space is available. The cross section of the **MMRS** series high precision locknuts, which otherwise have the properties of the MMRBS series, was designed to match the 60° ball screw support bearings of the BS... series and the MD seal ring locknut (see pages 12 to 14).

A further alternative to fitting separate contact seals is the use of an integrated labyrinth seal. This range of technical possibilities allows the user to realise a whole variety of options. And the result here is increased efficiency.

The locknuts are available in standard sizes and in special cross sections as well as in variations made of corrosion resistant steel or coated with ATCoat coating, see page 22 (**IBC Rolling Bearings With ATCoat Coating TI-I-5011.2**).

Production series of IBC precision locknuts and labyrinth seals	
MMR	narrow high precision locknut with radial locking
MMRB	wide high precision locknut with radial locking
MMRBS	like MMRB, but with laminar seal
MBA	high precision locknut with axial locking via slotted segments and pressure screw
MBAS	like MBA, but with laminar seal
MBC	high precision locknut with axial locking via slotted segments and clamping screw
MMA	high precision locknut with axial locking via 2 cones, only for small locknuts
MMRS	special high precision groove locknut with radial locking, matched to the 60° ball screw support bearings (BS...) and the MD high precision locknut
MD	high precision locknut with fine external thread, fits the S and MMRS series
S	precision labyrinth seal with spring steel laminar rings, matched to the MD seal ring nut

Table 1.1: Production series of IBC precision locknuts and labyrinth seals

1.2 Tolerances

As both the internal thread with its locking devices and the face are ground by precision finishing in a single clamping operation, IBC high precision locknuts attain a high axial face runout according to IT3 or better, ISO standard tolerance classes according to German standard DIN 7151.

The locking devices, which are also profiled, bear on the flanks of the thread. The thread is manufactured with a tolerance of 4H according to German standard DIN 13 T21-24; from M210x4 the tolerance is 6H.

1.3 Mounting dimensions

The recommended tolerance of the shaft counter thread is "medium" according to 6g and 6h; it is "fine" according to 4h for higher accuracy requirements (machine tools).

1.4 Strength of the locknut threads

The axial strengths specified below are applicable to shaft threads with a tensile strength of at least 700 N/mm². In the case of dynamic load, 75% of axial strength is permissible.

Threads up to M50: 1,000 N/mm²

Threads exceeding M50: 650 N/mm²

1.5 Mounting

An IBC high precision locknut should be screwed on with all locking devices in an unchanged position. Use a hook spanner or a socket wrench to tighten the locknut with approximately double the tightening torque T to avoid settling. The required tightening torque depends on the required preload of the high precision bearing and the required press fit. Then loosen the precision locknut again, and retighten it by applying the minimum required preload torque M_D .

For most bearing series the locknuts can abut directly to the inner bearing ring. An exception, however, applies to the use of spindle bearings of the 718... series. Because of the overall size of the corresponding locknut, you should check whether the use of a spacer ring is called for, to ensure that clamping via the inner ring can be achieved (see page 21, fig. 7.6, examples of application).

Chapter 6, page 15 onwards, contains detailed information on calculation as well as further mounting advice

1.6 Securing against loosening

IBC precision locknuts are supplied with two different securing systems, depending on the specific design.

Both types share a basic technical concept, however, which ensures that the shaft thread and the locknut are not damaged during mounting and securing. You will therefore be able to loosen and relock them without doing any damage.

Precision locknuts with radial locking (MMR, MMRB, MMRS) have a number of fixing screws on their outer diameter, which are used to radially clamp brass locking devices with the nut thread machined into them, in the shaft thread (see fig. 1.6.1).

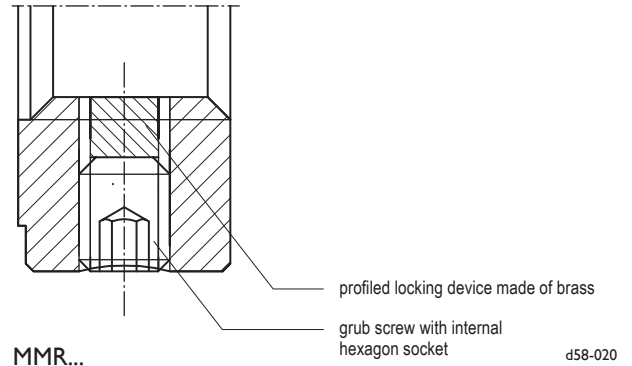

MMR...

Fig. 1.6.1: Detail drawing of the MMR securing system

The MBA and MBC precision locknuts are axially secured with slotted segments that are integrated into the locknut and have the nut thread machined into them. These segments are elastically deformed axially via grub screws. As a result, they clamp against the flanks of the shaft thread (see fig. 1.6.2).

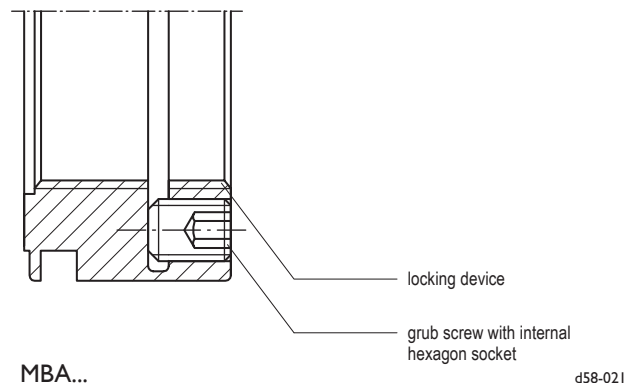

MBA...

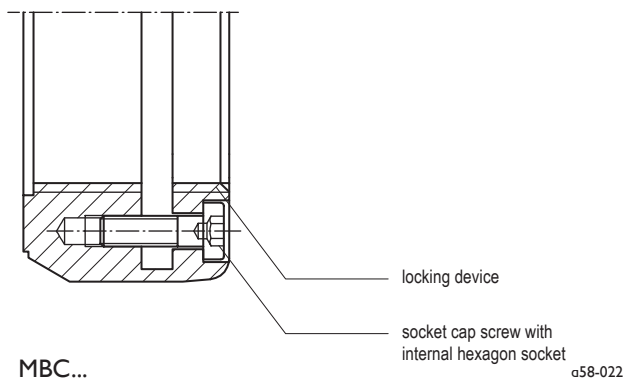

MBC...

Fig. 1.6.2: Detail drawing of the MBA and MBC securing systems

In principle, you should follow the procedure described below for both securing systems:

First, tighten the fixing screws in a crosswise sequence. Tighten each screw until you can feel some resistance. Then retighten the fixing screws in a crosswise sequence. Tighten the screws with 30% and then with 70% tightening torque, and finally fasten them with the minimum required tightening torque M_A .

The maximum permissible tightening torques M_A for grub screws and internal hexagon socket screws are contained in table 1.6 below.

Once the locking devices have been tightened with tightening torque M_A , high loosening torques will prevent unintended loosening in the case of spindles alternating between clockwise and counter-clockwise operation as well as in the case of extremely fast acceleration of the spindle.

1.7 Dismounting

In order to dismount the locknut, first slightly loosen the locking devices in an even manner. As the profiled brass locking devices and the slotted segments are not deformed during clamping, the precision locknut may be re-used repeatedly after loosening without loss of precision.

Locking thread	Width across flats		Maximum tightening torque M_A		
	S_{MBA} S_{MMR} S_{MMRB} S_{MMRS}	S_{MBC}	Grub screw with internal hexagon socket		Socket cap screw with internal hexagon socket
			MMR/MMRB MMRS	Nm	MBA
	mm				
M4	2	3	2	2	4.5
M5	2.5	4	4	4	8.5
M6	3	5	7	7	15
M8	4	6	18	9	36
M10	5	-	34	15	-
M12	6	-	60	36	-
M14	6	-	85	45	-

Table 1.6: Maximum permissible tightening torques M_A for grub screws and internal hexagon socket screws



Fig. 1.6.3: IBC precision locknuts of the series MBC and MBA in comparison

2. IBC precision locknuts MMR, MMRB / MMRBS

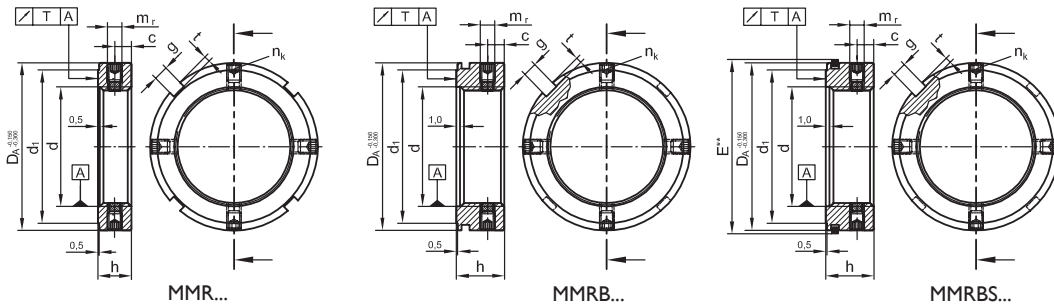

x58-101

Thread	Series	Dimensions										Max. tightening torque of lock screws MMR, MMRB / MMRBS M_A Nm	Permissible axial load MMR, MMRB / MMRBS F_a kN
		D_A	h	g	t	d_1	c	m_r	h_1	h_2	E^{**}		
M 6 x 0,5	MMR 6	16	8	3	2	12	4	M 4				2	16
M 8 x 0,75	MMR 8												17
M 10 x 0,75	MMR 10	18				14							22
M 10 x 1	MMR 10 x 1												22
M 12 x 1	MMR 12	22				18							26
M 15 x 1	MMR 15	25				21							33
M 16 x 1,5	MMR 16 x 1,5	28	10	4		23	5						37
M 17 x 1	MMR 17							M 5				4	49
M 20 x 1	MMR 20	32				27							55
	MMRB 20		16						4.7	1.5	32		110
M 20 x 1,5	MMR 20 x 1,5		10										70
	MMRB 20 x 1,5		16								32		110
M 25 x 1,0	MMR 25 x 1,0	38	12	5		33	6	M 6				7	87
M 25 x 1,5	MMR 25												87
	MMRB 25		18						5.1	1.9	38		130
M 30 x 1,5	MMR 30	45	12			40							110
	MMRB 30		18							1.6	45		150
M 33 x 1,5	MMR 33		12										130
M 35 x 1,5	MMR 35	52				47							120
	MMRB 35		18							1.5	52		170
M 40 x 1,5	MMR 40	58	14	6	2.5	52	7						150
	MMRB 40		20								58		210
M 42 x 1,5	MMR 42		14										150
M 45 x 1,5	MMR 45	65				59							170
	MMRB 45		20						5.5	1.5	65		240
M 50 x 1,5	MMR 50	70	14			64							180
	MMRB 50		20						6	2.3	70		260
M 55 x 2	MMR 55	75	16	7	3	68	8	M 8				18	250
	MMRB 55		22							2	75		340
M 60 x 1,5	MMR 60 x 1,5	80	16			73							270
M 60 x 2	MMR 60												270
	MMRB 60		22								80		360
M 65 x 1,5	MMR 65 x 1,5	85	16			78							290
M 65 x 2	MMR 65												290
	MMRB 65		22								85		400
M 70 x 2	MMR 70	92	18	8	3.5	85	9						350
	MMRB 70		24								92		470
M 75 x 2	MMR 75	98	18			90							370
	MMRB 75		24								98		500
M 80 x 2	MMR 80	105	18			95							390
	MMRB 80		24						6.3	1.5	105		520
M 85 x 2	MMR 85	110	18			102		M 10				34	400
	MMRB 85		24								110		540

Thread	Series	Dimensions										Max. tightening torque of lock screws	Permissible axial load	
		d	D _A	h	g	t	d ₁	c	m _r	h ₁	h ₂			E**
Tolerance 4H	with radial locking	mm										M _A	F _a	
												Nm	kN	
M 90 x 2	MMR 90	120	20	10	4	108	9	M 10					34	470
	MMRB 90		26						7	2.2	120			610
M 95 x 2	MMR 95	125	20			113								490
	MMRB 95		26								125			640
M 100 x 2	MMR 100	130	20			120								510
	MMRB 100		26						7	2.2	130			660
M 105 x 2	MMR 105	140	22	12	5	126								560
	MMRB 105		28						7.5	2.7	140			700
M 110 x 2	MMR 110	145	22			133								600
	MMRB 110		28								145			770
M 115 x 2	MMR 115	150	22			137								660
	MMRB 115		28								150			820
M 120 x 2	MMR 120	155	24			138								710
	MMRB 120		30								155			890
M 125 x 2	MMR 125	160	24			148								740
	MMRB 125		30								160			920
M 130 x 2	MMR 130	165	24			149								760
	MMRB 130		30						7.5	2.6	165			950
M 135 x 2	MMR 135	170	24			155								820
	MMRB 135		30								170			1010
M 140 x 2	MMR 140	180	26	14	6	160	10	M 12					60	880
	MMRB 140		32								180			1080
M 145 x 2	MMR 145	190	26			171								920
M 150 x 2	MMR 150	195												930
	MMRB 150		32								195			1040
M 160 x 3	MMR 160	205	28	16	7	182								1050
	MMRB 160		34						8.5	2.7	205			1360
M 165 x 3	MMR 165	210	28			193								1075
M 170 x 3	MMR 170	220				198	14							1125
	MMRB 170		34								220			1430
M 180 x 3	MMR 180	230	30	18	8	203	15							1260
	MMRB 180		36								230			1600
M 190 x 3	MMR 190	240	30			214								1300
	MMRB 190		36								240			1670
M 200 x 3	MMR 200	250	32			226	16							1440
	MMRB 200		38								250			1850
M 210 x 4	MMRB 210	270	40	20	10	238	14	M 14	10		270	85		2000
M 220 x 4	MMRB 220	280				250					280			2250
M 240 x 4	MMRB 240	300	44			270					300			2300
M 260 x 4	MMRB 260	310				290					310			2500
M 280 x 4	MMR 280	330	26	24		310	12							1235
M 280 x 4	MMRB 280		50				15			2.6	330			2850
M 300 x 5	MMRB 300	360				336					360			3100

Further sizes available on request

Runout T according to IT3, German standard DIN 7151

* from Ø 200: 6H

n_k: number of clamping devices = 4

MMRBS = MMRB + laminar spring steel rings (labyrinth seal)

E** = cross section of housing connection = $D_A + \frac{0.1}{0}$

D_A with a 25° lead-in chamfer for the seal (see MMRS as well), whose introductory cross section is 4% larger than D_A

A special design of the MMR locknut is available that has a back that is ground plane-parallel to the side of tightening (MMR-PR...)

This enables the axial runout of a rolling bearing to be measured directly at the locknut

It also provides the option of connecting further parts to this locating face

3. IBC precision locknuts MBA / MBAS, MBC, MMA

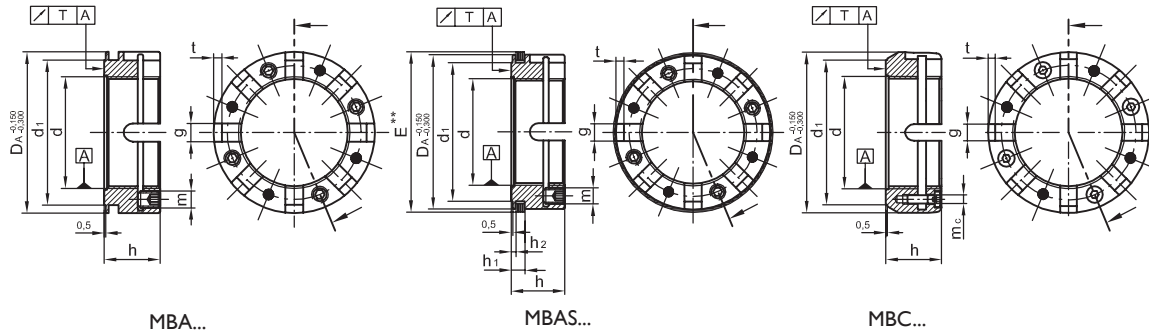

x58-102

Thread	Series MBA/MBAS, MBC, MMA	Dimensions										Max. tightening torque of lock screws		Permissible axial load MMA MBA MBC F _a	
		D _A	h	g	t	d ₁	m	m _c	h ₁	h ₂	E**	MBA M _A	MBC		kN
d		mm										Nm			
Tolerance 4H	with axial locking														
M 17 x 1	MMA 17 **	28	16	4	2	23	M 4						2		70
M 20 x 1	MBA 20 ***	32				27			4.7	1.5	32				110
M 20 x 1.5	MBA 20 x 1.5 ***														110
M 25 x 1.5	MBA 25	38	18	5		33			5.2	2	38				130
M 30 x 1.5	MBA 30	45				40	M 6		5	1.5	45	7			150
M 35 x 1.5	MBA 35	52				47					52				120
M 40 x 1.5	MBA 40	58	20	6	2.5	52					58				150
M 45 x 1.5	MBA / MBC 45	65				59		M 4	5.5	1.5	65		4.5		170
M 48 x 1.5	MBA 48 x 1.5	70				64									180
M 50 x 1.5	MBA / MBC 50								6	2	70				180
M 55 x 2	MBA / MBC 55	75	22	7	3	68	M 8				75	9			250
M 60 x 2	MBA / MBC 60	80				73					80				270
M 64 x 2	MBA 64	85				78					85				290
M 65 x 2	MBA / MBC 65														290
M 70 x 2	MBA / MBC 70	92	24	8	3.5	85		M 5			92		8.5		350
M 75 x 2	MBA / MBC 75	98				90					98				370
M 80 x 2	MBA / MBC 80	105				95			6.7	2	105				390
M 85 x 2	MBA / MBC 85	110				102	M 10				110	15			400

Further sizes available on request

** Locking: 2 cones under 90°

*** Locking: 3 locking devices and 6 hook grooves

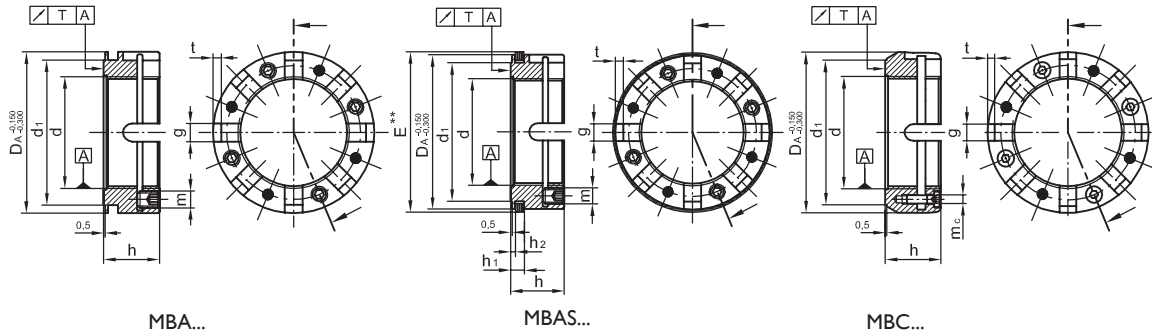

x58-102

Thread	Series	Dimensions										Max. tightening torque of lock screws		Permissible axial load
		D _A	h	g	t	d ₁	m	m _c	h ₁	h ₂	E**	MBA M _A	MBC	
d	MBA/MBAS MBC	mm										Nm		kN
Tolerance * 4H	with axial locking													
M 90 x 2	MBA / MBC 90	120	26	10	4	108	M 10	M 5	6.7	2	120	15	8.5	470
M 95 x 2	MBA / MBC 95	125				113					125			490
M 100 x 2	MBA / MBC 100	130				120		M 6			130		15	510
M 105 x 2	MBA / MBC 105	140	28	12	5	126					140			560
M 110 x 2	MBA / MBC 110	145				133					145			600
M 115 x 2	MBA / MBC 115	150				137			6.9		150			660
M 120 x 2	MBA / MBC 120	155	30			138					155			710
M 125 x 2	MBA / MBC 125	160				143					160			740
M 130 x 2	MBA / MBC 130	165				149			7.4	2.5	165			760
M 135 x 2	MBA 135	170				154								780
M 140 x 2	MBA / MBC 140	180	32	14	6	160	M 12	M 8			180	36	36	880
M 145 x 2	MBA 145	185				160					185			900
M 150 x 2	MBA / MBC 150	195				165					195			930
M 160 x 3	MBA / MBC 160	205	34	16	7	182			8.3		205			1020
M 170 x 3	MBA / MBC 170	220				198 / 193					220			1075
M 180 x 4	MBA / MBC 180	230	36	18	8	203					230			1200
M 190 x 3	MBA / MBC 190	240				214					240			1250
M 200 x 3	MBA / MBC 200	250	38			226					250			1390
M 210 x 4	MBA / MBC 210	270	40	20	10	238	M 14		10.2	3	270	45		1500
M 220 x 4	MBA / MBC 220	280				250					280			1685
M 240 x 4	MBA / MBC 240	300	44			270					300			1720
M 260 x 4	MBA / MBC 260	310				290					310			1875
M 280 x 4	MBA / MBC 280	330	50	24		310			10.3		330			2130
M 300 x 4	MBA / MBC 300	360				336								2325

Further sizes available on request

Runout T according to IT3, German standard DIN 7151

* from Ø 200: 6H

n_k: number of clamping devices = 4

MBAS = MBA + laminar spring steel rings (labyrinth seal)

E** = cross section of housing connection = $D_A + \frac{0.1}{0}$ and a 25° lead-in chamfer for the seal (see MMRS as well), whose introductory cross section is 4% larger than D_A

4. IBC precision labyrinth seals S series

IBC precision seal ring locknuts MD series

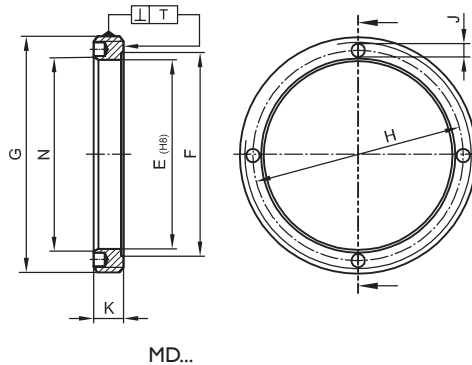
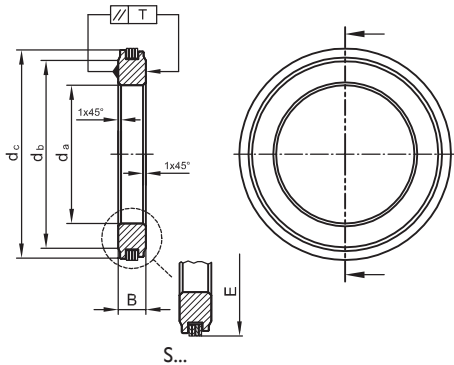

x58-103

Series	Dimensions				Series	Dimensions							Permissible axial load F _a kN
	d _a	d _b	d _c	B		MD	E	F	G	H	J	K	
S 12-26	12	21	25.5	7	MD 40-26	26	28	M 40 x 1.5	32	4.3	9	27	45
S 15-26	15												
S 17-36	17	26	35.5		MD 50-36	36	41	M 50 x 1.5	42.5		10	37.5	65
S 20-36	20												
S 25-40	25	32	39.5		MD 55-40	40	45	M 55 x 1.5	47			42	77
S 25-50		41	49.5	10	MD 70-50	50	55	M 70 x 1.5	59.5		12	53.73	100
S 30-50	30												
S 30-60		46	59.5		MD 80-60	60	65	M 80 x 1.5	72			63	130
S 35-60	35												
S 35-76		66	75.5	12	MD 110-76	76	92	M 110 x 2	90	6.3	14	79.5	190
S 40-60	40	50	59.5	10	MD 80-60	60	65	M 80 x 1.5	72	4.3	12	63	130
S 40-76-10		66	75.5		MD 95-76	76	82	M 95 x 2	84.5			79.5	150
S 40-76				12	MD 110-76		92	M 110 x 2	90	6.3	14		190
S 45-60	45	55	59.5	10	MD 80-60	60	65	M 80 x 1.5	72	4.3	12	63	130
S 40-66			65.5		MD 85-66	66	72	M 85 x 1.5	76			69	
S 45-66		60											
S 45-76		66	75.5	12	MD 110-76	76	92	M 110 x 2	90	6.3	14	79.5	190
S 50-76-10	50	68		10	MD 95-76		82	M 95 x 2	84.5	4.3	12		150
S 50-76				12	MD 110-76		92	M 110 x 2	90	6.3	14		190
S 55-76-10	55			10	MD 95-76		82	M 95 x 2	84.5	4.3	12		150
S 55-76				12									
S 55-99		86	98.5		MD 130-99	99	110	M 130 x 2	112	6.3	14	103	220
S 60-99	60												
S 70-99	70												
S 75-99	75				MD 120-99		101	M 120 x 2					210
S 75-99-10				10									
S 80-132	80	114	131.5	14	MD 175-132	132	147	M 175 x 3	153	8.3	24	137.3	495
S 80-132-16				16									
S 80-132-24				24									
S 85-132	85			14									
S 90-132	90												
S 100-132	100				MD 160-132		134	M 160 x 3	148	6.3	18	137.3	340
S 100-162		142	161.3	24	MD 220-162	162	172	M 220 x 3	190	10.3	24	170	620
S 110-132	110	120	131.5	14	MD 160-132	132	134	M 160 x 3	148	6.3	18	137.3	340
S 127-162	127	144	161.3	14.5	MD 190-162	162	167	M 190 x 3	176			166	440

Further sizes available on request

The non-contact sealing elements of the S series consist of a ground, plane-parallel steel ring with a radial circumferential groove, in which spring steel laminar rings are fitted. The laminar rings are surrounded by a grease pack (GH62).

During mounting, the sealing elements are pressed into the bore of a matching precision seal ring locknut of the MD series, or into a housing bore, via an lead-in chamfer, thereby fixing them in their position. The spacer ring (supporting ring) of the labyrinth seal that is positioned on the shaft will now turn without making

contact with the spring rings. A grease pack in the groove will prevent the spring rings from axially running up against the axial shoulders.

Practice has shown that placing labyrinth seals next to rolling bearings provides an advantage if the bearings are preloaded via the seals (angular contact ball bearings and 60° ball screw support bearings).

It is also possible to lock an MD precision seal ring nut externally and radially (see page 20, fig. 7.2).

In addition to the sealing units mentioned above, IBC also manufactures this type of seal for use with floating bearings as well as for other types of usage:

Series S	Dimensions			B
	d_a	d_b	d_c	
	mm			
S 30 - 72	30	46	71.5	12
S 35 - 72	35	46	71.5	12
S 35 - 99	35	66	98.6	12
S 40 - 72	40	50	71.5	12
S 40 - 99	40	66	98.6	12
S 40 - 100	40	66.5	98.6	12
S 45 - 75	45	55	74.5	12
S 45 - 99	45	66	98.6	12
S 50 - 99	50	68	98.6	12
S 65 - 105	65	100	104.5	12
S 65 - 120	65	105	119.50	12
S 80 - 115	80	102	114.50	12
S 82 - 99 - 10	82	90	98.6	10
S 85 - 130	85	105	129.5	12
S 90 - 130	90	105	129.5	12
S 140 - 180 - 12	140	160	179.5	12
S 180 - 220 - 14	180	200	219.5	14

Table 4.1: S series labyrinth seals used to seal directly against the housing (floating bearings). Further sizes are available on request

Examples of application: floating bearing function with S 40-100 labyrinth seal; see page 21, fig. 7.5, examples of application.
Ball screw floating bearing with BS 40M100.P4A.DTM.
S 40-76 labyrinth seal and MBA 40 precision locknut.

Please note: for floating bearings with a long displacement path, the side surfaces and the laminar rings must additionally be coated with anti-friction coating (GL). The width of the groove in the laminar carrier may also have to be adjusted to fit the overall displacement path.

The cylindrical slide in the housing should also have the lowest possible roughness for this type of application ($R_a \leq 0.4 \mu\text{m}$; from $\varnothing 80 \text{ mm}$: $R_a = 0.8 \mu\text{m}$); it should additionally be greased, or it should be coated in order to prevent corrosion.

The MD series seal ring nuts with external thread can be used separately to lock bearing outer rings or other machine parts. Because they do not have any locking devices they need to be secured by other means, e.g. with thread locker or with further machine parts, as shown on page 20, fig. 7.2, examples of application.

The inner diameter of the MD series seal ring nut has been matched to the IBC S series precision labyrinth seal; the nut can therefore be combined with the seal.

Like all IBC locknuts, the MD series has an axial face runout T of the mounting surface to the thread that is in accordance with IT3 (German standard DIN 7151).



Fig. 4: Seal ring from the MD series coated with ATCoat, see page 22

5. IBC precision labyrinth groove locknuts MMRS

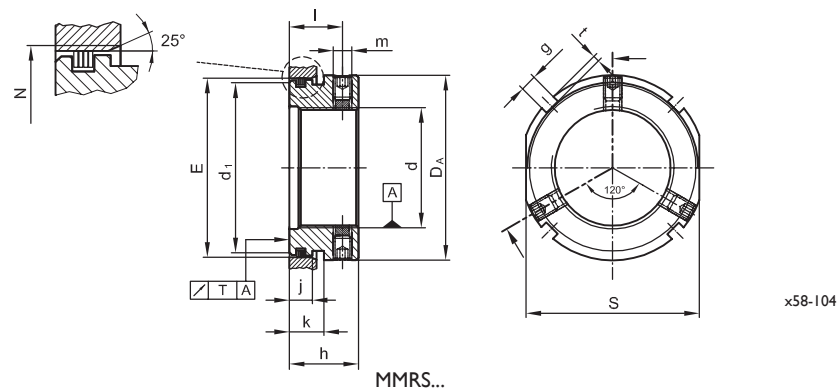

Thread	Series	Dimensions												Max. tightening torque of lock screws	Permissible axial load
		d	MMRS	E	DA	h	g	t	d1	l	m	j	k		
Tolerance 4H		mm												Nm	kN
M 17 x 1	MMRS 17-36	36	38	20	5	2	32	15.5	M 5	9	11	37.5	36	4	100
M 20 x 1	MMRS 20-36									8.5	11.5				110
M 22 x 1	MMRS 22-36									9	11				110
M 25 x 1.5	MMRS 25-50	50	58	25	6	2.5	46	19	M 6	10	13	52	55	7	150
M 27 x 1.5	MMRS 27-50														
M 30 x 1.5	MMRS 30-50														180
M 30 x 1.5	MMRS 30-60	60	70	28			56	21	M 8			63	65	18	190
M 35 x 1.5	MMRS 35-60														210
M 40 x 1.5	MMRS 40-60														260
M 35 x 1.5	MMRS 35-76	76	80	30	7	3	72	23			15	79.5	75		290
M 40 x 1.5	MMRS 40-76														340
M 45 x 1.5	MMRS 45-76														400
M 50 x 1.5	MMRS 50-76														420
M 55 x 2	MMRS 55-76														450
M 60 x 2	MMRS 60-76														480
M 55 x 2	MMRS 55-99	99	105		8	3.5	95					103	95		450
M 60 x 2	MMRS 60-99														480
M 65 x 2	MMRS 65-99														
M 75 x 2	MMRS 75-99														510
M 80 x 2	MMRS 80-132	132	140	46	12	5	114	35	M 10	21	25	137.5	135	34	810
M 100 x 2	MMRS 100-132			35			128	27		12	19				710
M 100 x 2	MMRS 100-162	162	170	46	16	7	142	35		21	25	168.5	160		1000
M 125 x 2	MMRS 125-162		175	35			158	27		12	19				800

Runout T according to IT3 (DIN 7151) n_c : number of clamping devices = 3

Further sizes available on request

A precision labyrinth groove locknut and the integrated laminar spring steel rings form a non-contact seal when used together with a matching housing or with an MD series seal ring nut (see page 21, fig. 7.4, examples of applications). While the labyrinth groove locknut turns on the shaft, its spring steel rings are fixed in their position, and the rings are also radially preloaded in an outward direction by the housing.

The free space should be filled with the same grease that is used with the bearings. The sealing area of the labyrinth groove nut has already been greased with BearLub GH62 grease, which has proved its worth with ball screw support bearings. Two additional spanner flats, which have been added facing each other, will make mounting easier. The MMRS locknut is especially widely used with single and double row 60° ball screw support bearings and in precision bearing units.

(For detailed information see our catalogue **Ball Screw Support Bearings TI-I-5010.3**)

6. Mounting and preloading IBC precision bearings with IBC precision locknuts

The main area of application for IBC high precision locknuts is precise applications, especially in machine tools and other high precision machines. The following section contains information on how to determine the tightening torques and how to use them during mounting. In these examples IBC precision locknuts are used, firstly, to preload angular contact ball bearings or tapered roller bearings and, secondly, in order to adjust the radial clearance of cylindrical roller bearings with tapered bore.

6.1 Preparation

Make sure the mounting environment is clean and all parts that are to be mounted, e.g. the bearing, spacer rings, the shaft, the housing and the precision locknut, are also clean (free of chips, grinding burrs or dents).

6.2 Checking the adjacent parts

In order to make sure that you achieve interference fits and a perpendicularity of the bearing seat after mounting, you should check the adjacent parts for dimensional stability and roughness. Check the parallel alignment of the spacer rings as a function of the high precision bearing bore diameter d in accordance with the following table:

Bore diameter d mm	Parallel alignment of rings μm
up to 150	2
from 150 to 250	4
from 250 to 500	6

Table 6.2: Parallel alignment of the spacer rings as a function of the high precision bearing bore diameter

Check the shaft thread and the nut thread before mounting to see whether you will be able to screw them on far enough.

6.3 Mounting

Rotating inner rings of spindle bearings and ball screws usually have an interference fit on the inner ring (press fit or shrink fit). As the pressing forces are not very great in the case of small bearings despite the use of an interference fit, it is usually sufficient to add grease, oil or mounting paste to the shaft surface in order to reduce friction during mounting. For an easy assembly, and in order to avoid great fitting forces and tightening torques, you can alternatively heat the inner ring or the whole bearing. This is especially advisable whenever a bearing set is preloaded with a precision locknut. When fitting the bearing rings you should ensure that these are fitted tightly to the contact surface in order to avoid settling and misalignment.

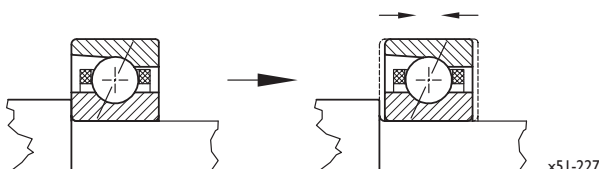

Fig. 6.3: Axial shrinking after cooling

Settling and misalignment would lead to premature failure, because the bearings would be operating without preload. If high precision rolling bearings have been fitted to the shoulder in a heated state, the bearing rings must be pushed axially against the shoulder once again after they have been allowed to cool, because the bearings shrink both radially and axially after cooling down (see fig. 6.3) For further details on mounting high precision bearings, please consult our catalogue **High Precision Bearings TI-I-5050**, Chapter 8: Mounting of high precision rolling bearings, page 176 onwards.

Mounting a bearing with an IBC precision locknut is carried out in two steps:

- overcoming the fitting forces, including the preload
- applying the preload, and securing against loosening

6.3.1 Mounting after heating the bearing

Bearings can be heated by means of various procedures. The linear coefficient of expansion for rolling bearings made of 100Cr6 is approximately $\alpha = 12 \cdot 10^{-6}/\text{K}$.

Thermal expansion $\delta = \alpha \cdot d \cdot \Delta T$		[mm] [6.1]
δ	thermal expansion	[mm]
α	coefficient of expansion	$\left[\frac{1}{\text{K}}\right]$
d	bore diameter	[mm]
ΔT	temperature difference	[K]

For the sake of the bearings, it is absolutely essential to make sure the temperature does not exceed 80 °C. The following diagram shows the required increase in temperature that corresponds to the bearing diameter and the desired fit.

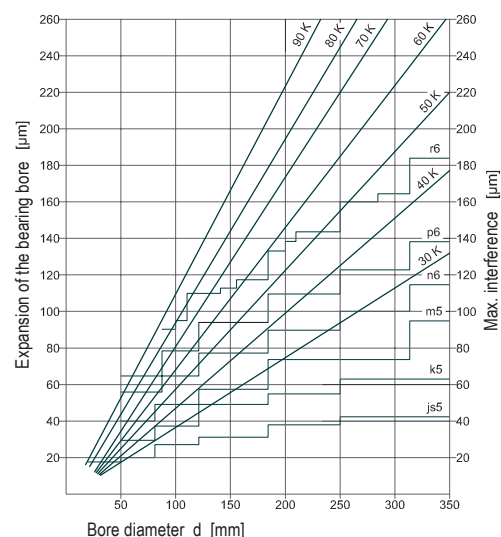

Diagram 6.3.1: Required temperature difference [K] for mounting the inner ring

6.3.2 Breakaway torques M_L of the precision locknut

The breakaway torque of the locknut should not be confused with the tightening torque of the locking devices. In cases where the breakaway torque of the locknut is insufficient because of load values that frequently fluctuate across a broad range, you should not further tighten the locknut but rather increase the tightening torque of the locking devices, should this be required. In determining the required tightening torque, you should keep in mind the fact that the maximum tightening torque M_A of the grub screws and internal hexagon socket screws is limited. This applies especially to the MBA and MBC production series. The relevant values are contained in the tables in Chapters 2 to 5, and in table 1.6.

The maximum breakaway torque [6.2] is determined by means of the following formula:

$$M_L = M_D + M_s \quad [\text{Nm}] \quad [6.2]$$

M_L	breakaway torque	[Nm]
M_D	min. required preload torque	[Nm]
M_s	breakaway torque from the tightening torque M_A of the locking devices	[Nm]

As can be seen, the breakaway torque increases in line with an increase in the tightening torque of the locking devices.

6.4 Calculating the locknut tightening torque T

The locknut tightening torque T [6.3] can be determined from the sum of the tightening torque T_a [6.4] that is required to fit the bearing plus the torque M_D [6.5] that is needed to preload the bearings.

$$T = T_a + M_D \quad [\text{Nm}] \quad [6.3]$$

6.4.1 Calculating the tightening torque T_a needed to fit the bearings

$$T_a = F_{\text{mont}} \left[\tan(\phi + \Psi) \cdot \frac{d_2}{2} + \mu_A \cdot \frac{D_m}{2} \right] \cdot 10^{-3} \quad [\text{Nm}] \quad [6.4]$$

T_a	tightening torque needed to fit the bearing	[Nm]
F_{mont}	bearing fitting force	[N]
ϕ	helix angle = $\frac{p}{\pi \cdot d_2}$	
Ψ	angle of friction = $\arctan \frac{\mu_G}{\cos \alpha}$	
p	thread pitch	[mm]
d_2	pitch diameter of the thread = $d - 0.6495 \cdot p$ (metr. thread)	[mm]
d	thread diameter from tables on pages 8 to 14	[mm]
μ_G	friction coefficient of thread (≈ 0.14)	
α	half the helix angle of the thread	
μ_A	friction coefficient of locknut locating face (≈ 0.14)	
D_m	mean diameter of the nut contact surface = $\frac{d_1 + d}{2}$	[mm]
	d_1 from tables on pages 8 to 14	

You can calculate F_{mont} , the axial force required to fit a bearing ring on a shaft with interference fit or retract it from this position, in the following way:

$$F_{\text{mont}} = \mu_B \cdot p_{\text{oberf}} \cdot \pi \cdot d_w \cdot B \quad [\text{N}] \quad [6.5]$$

F_{mont}	bearing fitting force	[N]
μ_B	friction coefficient of shaft/bore (~ 0.16)	
p_{oberf}	surface pressure	[MPa = N/mm ²]
d_w	shaft diameter	[mm]
B	bearing width	[mm]

The surface pressure p_{oberf} is calculated by means of the following formula (see also fig. 6.4.1 on page 17):

$$p_{\text{oberf}} = \frac{E}{2} \cdot \frac{\Delta d}{d_w} \cdot \frac{(1-k^2)(1-k_0^2)}{1-(d_o/D_i)} \quad [\text{MPa} = \text{N/mm}^2] \quad [6.6]$$

p_{oberf}	surface pressure	[MPa = N/mm ²]
E	Young's modulus shaft material	[N/mm ²]
Δd	effective overlap	[mm]
d_w	shaft diameter	[mm]
d_o	hollow shaft diameter	[mm]
D_i	mean raceway diameter	[mm]
k	wall thickness ratio of inner ring	$k = d/D_i$
k_0	wall thickness ratio of hollow shaft	d_o/d_w

In the case of solid shafts, the formula is simpler:

$$p_{\text{oberf}} = \frac{E}{2} \cdot \frac{\Delta d}{d_w} \cdot (1-k^2) \quad [\text{MPa} = \text{N/mm}^2] \quad [6.7]$$

In both cases the effective overlap means that, if required, a "rise in temperature = reduction in overlap" may be taken account of in order to reduce the fitting forces.

The mean raceway diameter D_i of the inner ring is determined approximately by means of the following formula:

$$D_i = 0,21 \cdot (4d + D) \quad [\text{mm}] \quad [6.8]$$

D_i	mean raceway diameter	[mm]
d	bore diameter of the bearing	[mm]
D	outside diameter of the bearing	[mm]

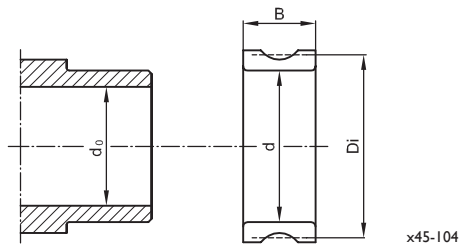

Fig. 6.4.1: The mean raceway diameter D_i

6.4.2 Calculating the minimum required preload torque M_D

The minimum required preload torque M_D for the bearings is a function of the ground-in nominal preload F_V of the bearing, the thread diameter and the mounting arrangement. In a mounted state the interference fit at the inner ring also has a determining impact, increasing preload.

The minimum required preload torque M_D is determined approximately by means of the following formula:

$$M_D = K_u \cdot d_{\text{Gewinde}} \cdot F_V \cdot K_{FV} \cdot 10^{-4} \quad [\text{Nm}] \quad [6.9]$$

M_D min. required preload torque [Nm]

K_u series-specific increase factor (tables 6.4.2.1 to 6.4.2.5)

d_{Gewinde} thread diameter of precision locknut [mm]

F_V ground-in nominal preload [N]

K_{FV} factor of bearing arrangement
for F_V of the single bearing = 1 for bearing sets with F_V of preload for the bearing set

<>	DB	1	<<>>	QBC	2
<<>	TBT	1.36	<<<<>	PBT	1.71
<<<>	QBT	1.57	<<<<>	PBC	2.42

Amongst other things, the series-specific increase factor K_u takes account of the increase in preload torque that is due to the interference between the bearing rings and the shaft. Tables 6.4.2.1 to 6.4.2.4 contain the increase factors for IBC high precision spindle bearings with a contact angle α of 15° and 25° . Table 6.4.2.5 contains the increase factors K_u for our single row 60° ball screw support bearings of the BS... series.

Contact angle $C=15^\circ$; light preload (UL)						
Bore diameter		Increase factor				
d		K_u				
from	to	718...	719...	70...	72.../73...	
10	45	-	3.6	3.2	3.0	
50	95	3.0	3.0	2.9	2.8	
100	140	2.8	2.8	2.8	2.6	
150	190	2.7	2.7	2.6	-	
200	500	2.5	2.5	2.5	-	

Table 6.4.2.1: Increase factor K_u for the spindle bearings with a contact angle $C = 15^\circ$ and light preload (UL)

Contact angle $E=25^\circ$; light preload (UL)						
Bore diameter		Increase factor				
d		K_u				
from	to	718...	719...	70...	72.../73...	
10	45	-	4.6	4.6	4.4	
50	95	3.4	4.2	3.7	3.3	
100	140	3.0	3.8	3.1	3.0	
150	190	2.9	3.4	3.1	-	
200	500	2.7	3.1	2.8	-	

Table 6.4.2.2: Increase factor K_u for the spindle bearings with a contact angle $E = 25^\circ$ and light preload (UL)

Contact angle $C=15^\circ$; higher preload (UM, UH)						
Bore diameter		Increase factor				
d		K_u				
from	to	718...	719...	70...	72.../73...	
10	45	-	3.0	2.8	3.0	
50	95	2.9	2.9	2.6	2.5	
100	140	2.8	2.7	2.6	2.4	
150	190	2.7	2.7	2.5	-	
200	500	2.5	2.5	2.4	-	

Table 6.4.2.3: Increase factor K_u for the spindle bearings with a contact angle $C = 15^\circ$ and higher preload (UM, UH)

Contact angle $E=25^\circ$; higher preload (UM, UH)						
Bore diameter		Increase factor				
d		K_u				
from	to	718...	719...	70...	72.../73...	
10	45	-	4.0	3.0	3.0	
50	95	3.2	3.7	2.9	2.8	
100	140	2.8	3.0	2.8	2.6	
150	190	2.7	2.9	2.7	-	
200	500	2.5	2.6	2.5	-	

Table 6.4.2.4: Increase factor K_u for the spindle bearings with a contact angle $E = 25^\circ$ and higher preload (UM, UH)

BS... production series: single row 60° ball screw support bearings						
Bore diameter		Increase factor				
d		K_u				
from	to					
17	30	2.8				
35	75	2.6				
80	127	2.4				

Table 6.4.2.5: Increase factor K_u for the single row 60° ball screw support bearings of the BS... production series

You should, on principle, observe the maximum permissible axial force for high precision bearings with regard to the contact pressure, too. This force may not exceed a lateral contact pressure of approx. 10 MPa or 10 N/mm² in the area of the raceways, otherwise the raceways may become deformed and the precision locknut may be damaged by excessively high mounting forces. You must also observe any existing limit to the permissible tightening torque that applies to the specific bearing type you are using. The permissible contact pressure of the adjacent parts must also be taken into account, especially for housings made of aluminium. In this case, the axial force that is determined by means of the maximum permissible contact pressure must be greater than the preload force of the single bearing or the bearing set according to [6.9]. In calculating this value, you must take into account the effective area from the directional force from the bearing.

In order to avoid the occurrence of settling, it is advisable first to tighten precision locknuts or cap screws with double the tightening torque T , then to unfasten the nuts or screws, and finally to re-tighten them at the minimum required preload torque M_D .

6.4.3 Example: spindle bearing, from preload

A 7020.E.T.P2H.DBL bearing set with 630 N preload is pre-loaded with a MMR 100 precision locknut on a hollow shaft with an inner diameter of 80 mm and 2 μ m interference. First of all, calculate the bearing fitting force F_{mont} by means of the contact pressure, which is known.

$$D_i = 0.21 \cdot (4 \cdot 100 + 150) = 115.0 \text{ mm}$$

$$P_{Oberf} = \frac{210000}{2} \cdot \frac{0.002}{100} \cdot \frac{\left[1 - \left(\frac{100}{115.5}\right)^2\right] \cdot \left[1 - \left(\frac{80}{100}\right)^2\right]}{1 - \left(\frac{80}{115.5}\right)^2}$$

$$= 0.36 \text{ MPa or N/mm}^2$$

$$F_{mont} = \mu_B \cdot P_{Oberf} \cdot \pi \cdot d_w \cdot B$$

$$= 0.16 \cdot 0.36 \cdot \pi \cdot 100 \cdot 24 = 434 \text{ N}$$

(For comparison: a solid shaft with $p_{Oberf} = 0.53 \text{ N/mm}^2$ has a fitting force of 639 N)

In a second step, calculate the locknut tightening torque T :

$$\tan \Psi = \frac{\mu}{\cos \alpha} = \frac{0.14}{\cos 30^\circ} = 0.162 \rightarrow \Psi = 9.18^\circ$$

$$\tan \phi = \frac{2}{\pi \cdot 98.7}; \phi = 0.3696^\circ$$

$$D_m = (d_1 + d)/2$$

$$D_m \text{ of the precision locknut MMR 100} = 110 \text{ mm}$$

$$T_a = 434 \cdot \left[\tan(0.3696 + 9.18) \cdot \frac{98.7}{2} + 0.14 \cdot \frac{110}{2} \right] \cdot 10^{-3}$$

$$= 6.95 \text{ Nm}$$

$$M_D = 100 \cdot 630 \cdot 3.1 \cdot 1 \cdot 10^{-4} = 19.53 \text{ Nm}$$

$$T = T_a + M_D = 6.95 + 19.53 = 26.48 \text{ Nm}$$

Let us suppose the application-specific overlap is 8 μ m, and you are planning to reduce the effective overlap by heating. For a spindle bearing 7020 with approx. 8 μ m interference fit an increase in temperature of $\Delta T = 30 \text{ K}$ is sufficient to ensure the bearing can be slid on easily, also taking into consideration mounting speed.

6.4.4 Example: spindle bearing, from contact pressure

It is possible to determine the permissible axial loads and, as a result thereof, the maximum preload forces and the permissible tightening torques of bearings by taking into consideration the maximum lateral contact pressure for steel of approx. 10 N/mm². For the precision locknuts (MMR 100) described in this catalogue and their respective pitches the value would be 119 Nm for the example mentioned. In cases where the extent of interference is relatively great, the calculation method according to 6.4 needs to be used.

6.4.5 Example: ball screw bearing

Example of preloading BS 100M150.P4A.DBM single row 60° ball screw support bearings.

Tightening torque according to formula [6.9] for interference fit:

$$M_D = 2.4 \cdot 100 \cdot 10.500 \cdot 1 \cdot 10^{-4} = 252 \text{ Nm}$$

6.5 Mounting high precision rolling bearings with tapered bore

IBC high precision cylindrical roller bearings (**High Precision Bearings TI-I-5050**, pages 115 onwards) with tapered bore are slid directly on to the tapered part of the shaft. This process expands the inner ring of the high precision cylindrical roller bearing and reduces its bearing clearance δ_r . The clearance is further reduced by the fact that the outer ring is also mounted with a tight fit in the housing.

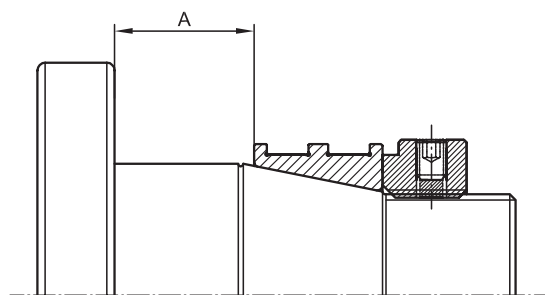

Fig. 6.5.1: Distance measurement

x52-106

The bearing clearance is carefully adjusted during the mounting process of the high precision cylindrical roller bearings with tapered bore so as to achieve flawless functioning with the desired speed, the highest possible system accuracy and the longest possible life time.

A lockable precision locknut is used to provide the axial pressure necessary for the adjustment process. The correct axial position of the bearing inner ring is ensured by a sleeve that is ground to

measure and is fitted to the shaft between the inner ring of the bearing and the bearing collar.

Determining the sleeve width A (fig. 6.5.1) requires accurate measuring; the individual steps must also be carried out very meticulously. In principle, there are two different approaches that need to be taken into consideration:

- The inner ring is slid on to the taper. During this process, the enveloping diameter over the roller and/or the raceway diameter is constantly measured until, taking into account the restriction of the outer ring and the way it reduces the bearing clearance, the total remaining bearing clearance corresponds to the required measurement. The remaining axial gap between inner ring and bearing collar then has to be measured with great accuracy, e.g. by feeling one's way with block gauges as shown in figure 6.5.2. Following this process, the inner ring is released from the tapered seat; a sleeve is ground to the dimension measured and is inserted. Then the assembly of the bearing is completed.
- Carrying out this process in multiple steps is more elaborate and also more conservative. As in the example above, the inner ring is first slid on to the tapered seat on its own, but is not fitted very tightly. The gap between the inner ring of the bearing and the shaft bearing-collar is then measured and the sleeve is made to measure. The enveloping diameter over the roller and/or the raceway diameter is then measured at the mounted inner ring that is clamped against the sleeve. The sleeve is now ground narrower step by step, and the inner ring is remounted after each step. After each step the measurements are recorded and further procedure is decided upon. This approach allows for a high degree of control and reduces subsequent settling.

Cylindrical roller bearings with tapered bore are fitted either with clearance, without clearance or with preload during mounting, depending on the bearing requirements. The value for the best possible mounting clearance or preload is speed-dependent.

More detailed information on the multiple-step procedure as well as on the setting values required in order to set the radial bearing clearance or preload is contained in our catalogue **High Precision Bearings TI-I-5050** on pages 180 onwards.



Fig. 6.5.2: Gap measurement

7. Examples of application for IBC precision locknuts and labyrinth seals

Securing a radially fixed precision locknut using the facility of a clearance hole in the housing. Clearance holes for pillow blocks are available on request.

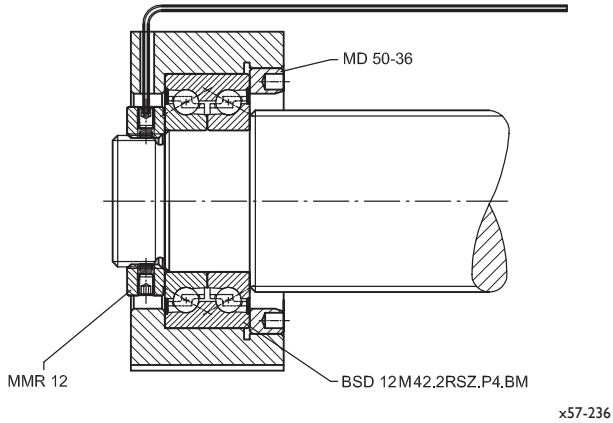

Fig. 7.1: Ball screw bearing with components from the IBC modular system

Bearing designation	Precision locknut	Precision seal ring nut
	MMR	MD
BSD 10M34	MMR 10	MD 40-26
BSD 12M42	MMR 12	MD 50-36
BSD 15M45	MMR 15	MD 50-36
BSD 17M47	MMR 17	MD 55-40
BSD 20M52	MMR 20	MD 55-40
BSD 25M57	MMR 25	MD 70-50
BSD 30M62	MMR 30	MD 70-50
BSD 30M72	MMR 30	MD 80-60
BSD 35M72	MMR 35	MD 80-60
BSD 40M75	MMR 40	MD 80-60
BSD 40M90	MMR 40	MD 95-76
BSD 50M90	MMR 50	MD 95-76
BSD 50M110	MMR 50	MD 120-99

Table 7.1: Possible combinations from the IBC modular system

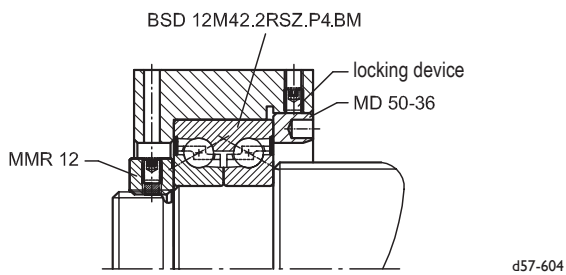

Fig. 7.2: Mechanical securing of an MD nut



Fig. 7.3: IBC precision locknut of the MMR series

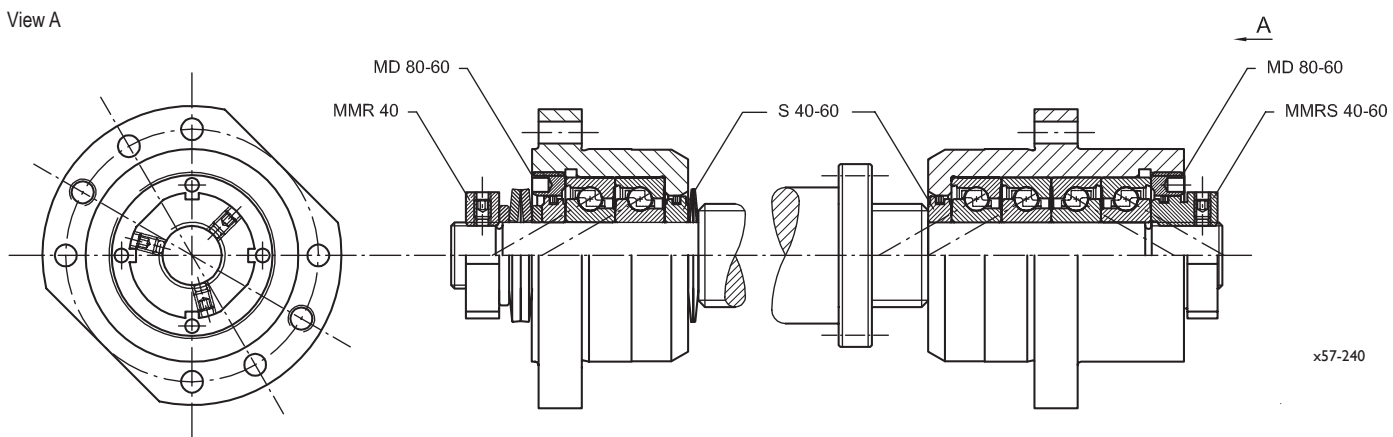

Fig. 7.4: Ball screw with bearings on both side, spring preloaded with labyrinth seals and securable precision locknuts

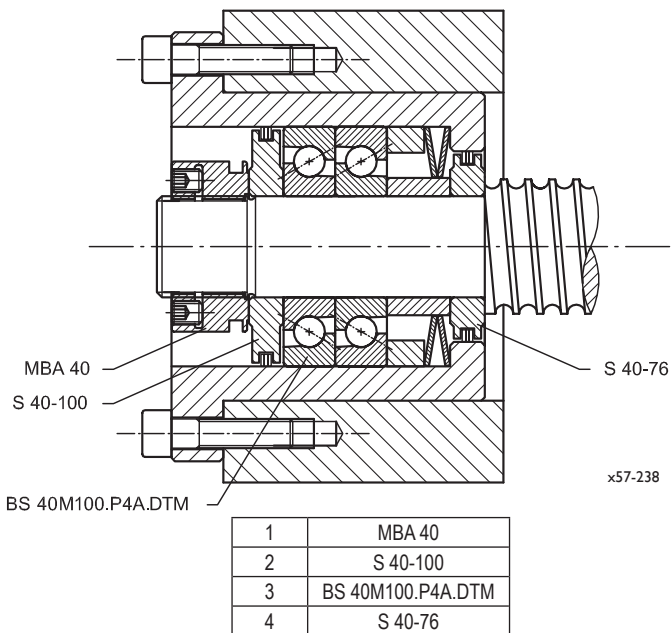

Fig. 7.5: Sealing of a spring-preloaded floating bearing on a ball screw with two S series labyrinth seals

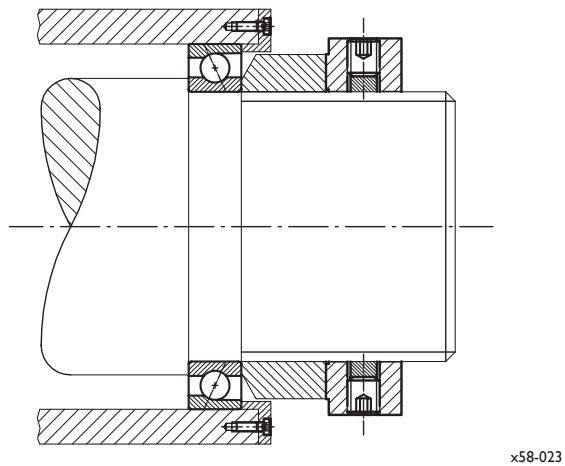

Fig. 7.6: Preloading of a spindle bearing with a small cross section via a spacer sleeve due to the available installation space

8. IBC precision locknuts and labyrinth seals coated with ATCoat coating



Fig. 8.1: Precision locknut of the MMR series coated with ATCoat coating

ATCoat coated precision locknuts and labyrinth seals

The material surface of machine parts is becoming more and more important to the overall performance of machines, power units and equipment. However, outside influences very often alter the surface quality of materials or corrode the surface material.

An ATCoat thin dense chromium coating protects the surface from outside environmental conditions and thereby increases the service life of precision locknuts and labyrinth seals as well as the life time of machines and equipment.

The advantages of this coating also include energy saving and an efficient use of material.

The ATCoat coating consists of 98% pure chrome. The chromium coating is extremely hard (between 72 and 78 HRC), free of cracks, firmly adhering, cone-shaped, precise, very thin, and highly pure. It can be deposited by a galvanic process on any of our precision locknuts and labyrinth seals (see fig. 8.2).

Because the process temperature during coating is below 80 °C there is no structural change to the basic material. The ATCoat coating is free of cracks and cone-shaped; this makes it much more resistant to corrosion than normal chromium coating.

Chrome also has very low wettability, a characteristic that enables it to repel aqueous media from its surface, enhancing resistance to corrosion even further.

The ideal coating thickness is between 2 to 4 µm thick, depending on the requirements of the components that are at risk of corrosion or abrasion. The thread flanks of precision locknuts and the groove of the precision seals are coated in a tapering manner.

The ATCoat coating provides very good protection against corrosion and wear and results in good rolling capacity. Because of its coating characteristics, the ATCoat coating can be used for critical rolling bearing applications. You will find further information on bearings coated with ATCoat coating in our brochure **IBC Rolling Bearings With ATCoat Coating TI-I-5011.2**.

The use of ATCoat coated locknuts (AC-...) and labyrinth seals will convert a standard mechanical engineering part into a higher-grade one with special protection against corrosion.

You can thereby avoid using expensive special materials and can also dispense with special-purpose manufacturing.

An ATCoat coating is very often applied to precision locknuts and labyrinth seals in the food and chemical industries, where the typical industrial application exposes the machine parts concerned to corrosive or aggressive media.

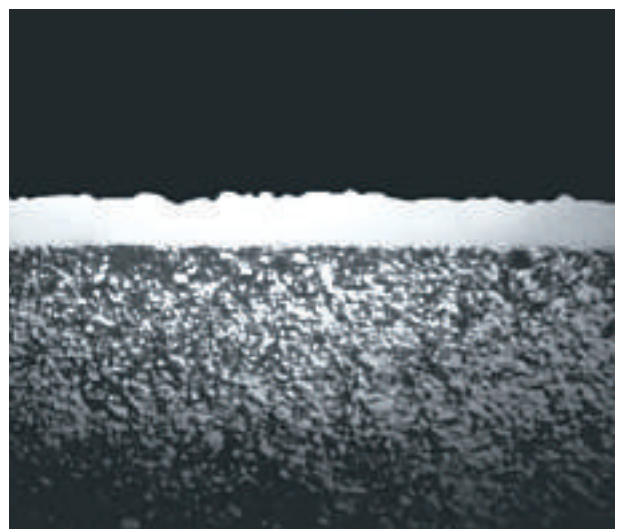
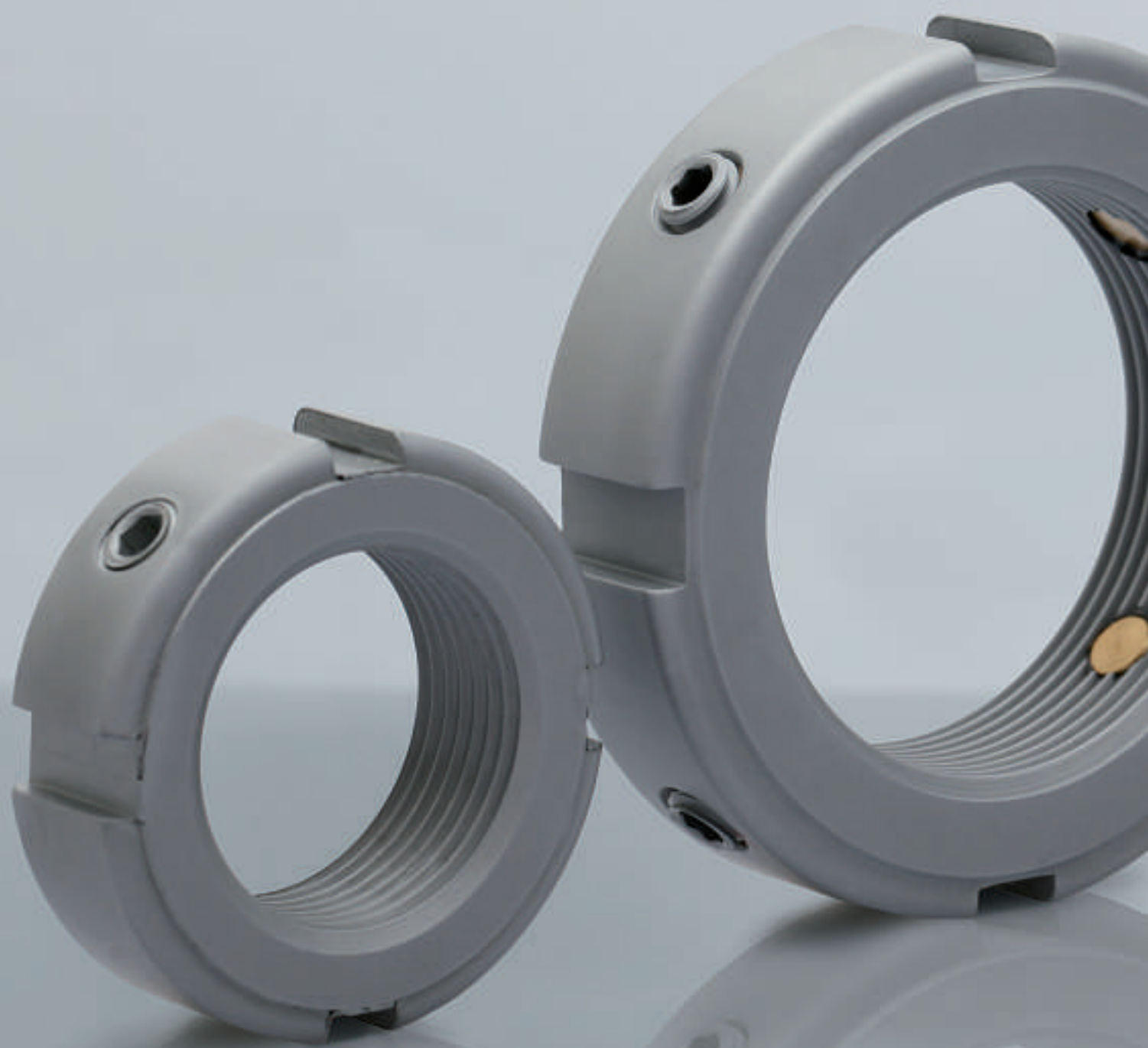

Fig. 8.2: Cross section of the ATCoat coating





IBC WÄRLZLAGER GMBH

INDUSTRIAL BEARINGS AND COMPONENTS

POSTFACH 1825 · 35528 WETZLAR (GERMANY)

Tel: +49/64 41/95 53-02
Fax: +49/64 41/5 30 15



Industriegebiet Oberbiel
D-35606 Solms-Oberbiel

e-mail: ibc@ibc-waelzlager.com

<http://www.ibc-waelzlager.com>

IBC INDUSTRIAL BEARINGS

AND COMPONENTS AG

Tel: +41/32/6 52 83 53
Fax: +41/32/6 52 83 58



Gibelstrasse 43
CH-2540 Grenchen

e-mail: ibc@ibcag.ch

<http://www.ibc-waelzlager.com>